

I/O System – 750 and 753 Series – One System for Every Application

General Product Information



One System for Every Application

The WAGO-I/O-SYSTEM 750/753 is characterized by its universal application scope and extensive product portfolio. With more than 500 different modules, the versatility and flexibility is so great that virtually every requirement in a wide range of industries is covered.

Industrial Automation

The comprehensive selection of I/O modules for different potentials and signal types saves time and money because the sensors/actuators can be wired directly – even in safety-related applications.

Building Automation

The broad portfolio enables flexible, cellar-to-ceiling solutions with conventional I/O modules, standardized industry-specific fieldbus protocols and subsystems for typical applications in lighting, shading, heating, HVAC and much more.

Marine and Onshore/Offshore Automation

International approvals coupled with industry-specific features permit use in shipbuilding and other harsh sectors. Addressing requirements inherent in specific industries and operating environments has enabled use on marine diesels and in the EMC-sensitive area of a vessel's bridge. Because the requirements are significantly greater for immunity to interference or emission of interference, along with superior mechanical performance in these sensitive areas, the WAGO-I/O-SYSTEM can readily meet the needs of other industries.

Process Automation

Even under the harshest environmental conditions, use is possible with special approvals. Potential hazardous area applications include oil and gas production, the chemical industry and power generation. The WAGO-I/O-SYSTEM can be installed in Zone 2/22 with its intrinsically safe I/O modules, making it possible to connect sensors/actuators in Zones 1/21 and 0/20.

Maximum Fieldbus Independence

The system's modularity is also reflected in its support for numerous fieldbus systems and ETHERNET standards. Depending on the application, it is possible to choose between fieldbus couplers and communication modules for different protocols.

Easy to Use

A modular, DIN-rail-mount design permits easy installation, expansion and modification of the I/O node without tools. The streamlined design prevents installation errors. In addition, proven CAGE CLAMP® technology offers fast, vibration-proof and maintenance-free connections that are independent of operator skill. Depending on the I/O module's granularity, field peripherals can be directly wired using 1-, 2-, 3- or 4-wire technology.

Worldwide Approvals

International approvals for building and industrial automation, as well as the process and marine industries, guarantee worldwide use – even under more rigorous operating conditions including ATEX, BR-Ex, IECEx, UL508, UL ANSI/ISA, AEx and numerous marine certifications.

Extremely Compact

WAGO's patented mechanical design leads to extremely compact I/O nodes. In fact, it can accommodate up to 16 channels in a module width of 12 mm (1/2").

- Finely granular I/O modules provide node customization.
- Space-saving design permits high integration density and direct connection.

Maximum Reliability and Ruggedness

The WAGO-I/O-SYSTEM is engineered and tested for use in the most demanding environments in accordance with the highest standards, e.g., those required in marine applications. The system is distinguished from other products that are solely intended for industrial use because of:

- Greatly increased vibration rating
- Significantly greater immunity to interference (ESD)
- Lower emission of interference
- Larger voltage fluctuation range
- Greater durability for continuous operation in upper temperature ranges

In addition, CAGE CLAMP® spring pressure connections ensure superior reliability. Integrated QA measures in the production process and 100% function testing ensure consistent quality.

Clear Identification

Module functionality is identified via integrated or pluggable marker carriers. Terminal assignment and technical data are printed onto the side of the I/O module. WAGO's WSB Marking System also allows for module- and channel-related identification.



Advantages:

- Fieldbus-independent – support all standard fieldbus protocols and ETHERNET standards
- Flexible platform adapts to diverse applications and environments
- Tested and approved worldwide
- Extensive range of accessories for marking systems and connection technologies
- Vibration-proof, fast and maintenance-free CAGE CLAMP® connections

I/O System – 750 and 753 Series Variants

Pluggable Connector

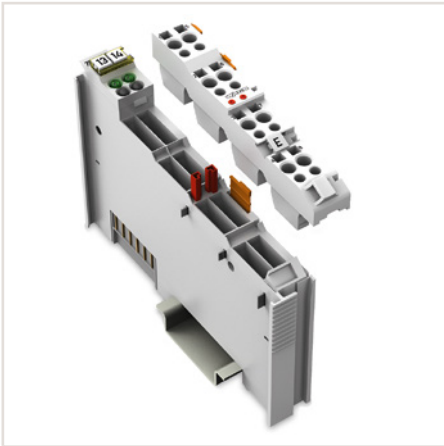

The pluggable connections of the WAGO-I/O-SYSTEM 753 allow quick and safe replacement. Optional coding pins prevent inserting the pluggable connector in the wrong I/O module. Replacing and connecting the I/O module requires no further action and eliminates possible errors – essentially serving as permanent wiring. Alternatively, field wiring is possible via interface modules that can be connected to the I/O system using a ribbon cable (see “Types”).

Functional Safety



In the European Union, the machinery directive defines the requirements for machine and system safety. This ensures a uniform standard for the protection of “life and limb” for people within a machine’s operating area.

The required risk assessment is based on harmonized standards (e.g., EN 13849) that identify existing risks and required risk reduction (SIL or PL quality). Based on the risk assessment, safety functionality can be implemented, e.g., by presence detection or protection zone violations using secure switches or light arrays to immediately shut down the “risk.” For this purpose, the safety signals are detected by the “yellow” safety modules and transmitted via “PROFIsafe” to the fail-safe PLC for further processing. The result is then executed via safe actuator (e.g., output module or controller).

The uniquely characteristic safety values of the WAGO modules facilitate calculation of the final safety function up to Cat. 4/PLe according to EN 13849, or SIL3 according to EN 62061 or IEC 61511.

The mixed operation of safe and conventional I/O modules streamlines system configuration. For increased electromagnetic immunity (EMC standard), WAGO offers compact power supply filter modules. Specific power supply features must be considered, which are described in detail in the corresponding manuals.

Use in Hazardous Areas



In many plants across the chemical and petrochemical industries, as well as in the production and process automation sectors, installations are operated that process explosive gas- or dust-air mixtures. This is why electrical equipment must be explosion-proof in order to avoid injuries to personnel and damage to facilities.

The modules within the WAGO-I/O-SYSTEM 750 are designed for use in both non-hazardous and hazardous areas.

The direct application of fieldbus technology in hazardous areas is typically resource-intensive. When used in hazardous areas of Zone 2/22, the WAGO-I/O-SYSTEM 750 offers a safe, easy and economical connection to the sensors and actuators of Zones 0/20 and 1/21. The “blue” Ex i I/O modules were specially developed for this purpose. They form an intrinsically safe section that can be integrated into a standard fieldbus node, offering all the advantages of state-of-the-art fieldbus technology. The WAGO-I/O-SYSTEM 750 is also approved for mining applications.

Extended Temperature Range

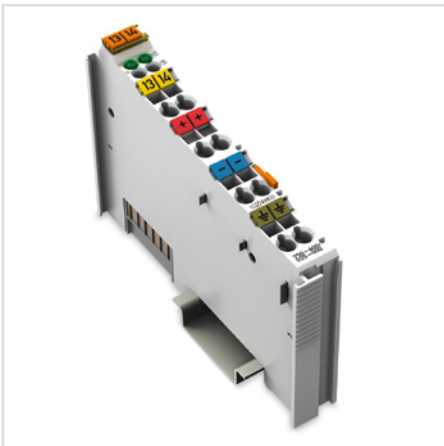

Industrial automation technology is typically operated in temperatures ranging from 0 °C to 55 °C. However, there are applications that require an extended temperature range. For these applications, WAGO offers a line of WAGO-I/O-SYSTEM 750 products for temperatures ranging from -20°C to +60°C. For extreme applications, where even this extended temperature range is not sufficient, the WAGO-I/O-SYSTEM 750 XTR is available.

I/O System – 750 and 753 Series Interfaces and Types

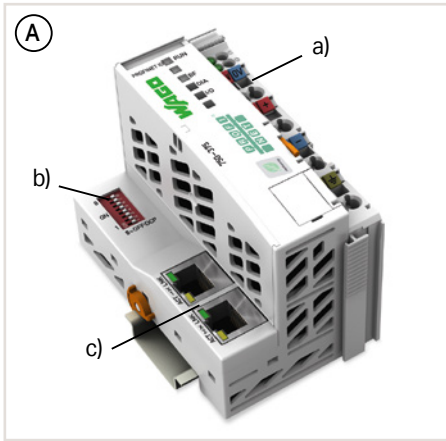

Housing design: fieldbus coupler (A)

- Including supply module (a) to power downstream I/O modules
- Technical differences on the connection level; optional addressing switch (b) and fieldbus interface (c)
- W x H x D (mm) 50.5 x 71.1 x 100 or
- W x H x D (mm) 61.5 x 71.9 x 100

Housing design: fieldbus coupler ECO (B)

- Restriction on power supply and data width
- W x H x D (mm) 49.5 x 71.9 x 96.8

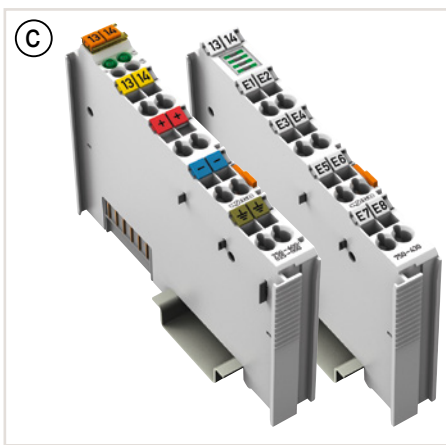
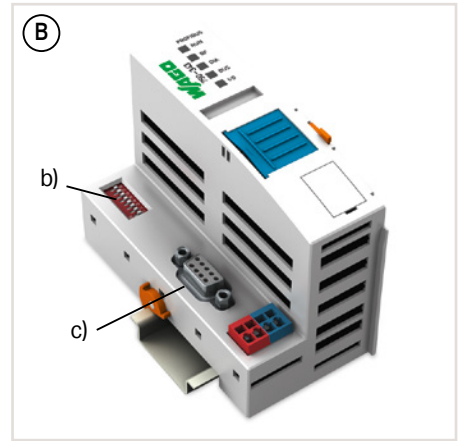

Housing design: 750 (C)

- 8 connection points (CAGE CLAMP®)
- W x H x D (mm) 12 x 69.8 x 100 (4 LEDs)
- W x H x D (mm) 12 x 67.8 x 100 (8 LEDs)

Housing design: 753 (D)

- Pluggable Connector
- 8 connection points (CAGE CLAMP®)
- W x H x D (mm) 12 x 69.8 x 100 (4 LEDs)
- W x H x D (mm) 12 x 69 x 100 (8 LEDs)
- Pluggable connectors and coding fingers are not included.

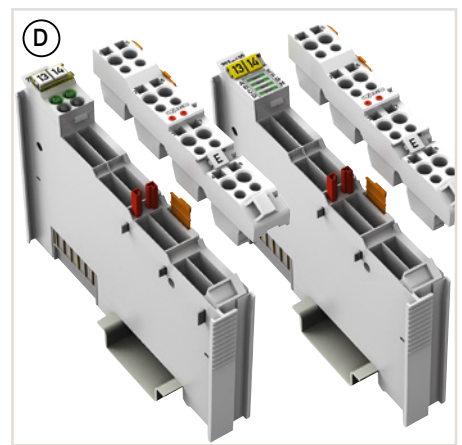

Housing design: 750 (E)

- 16 connection points (Push-in CAGE CLAMP®)
- W x H x D (mm) 12 x 69 x 100

Housing design (F)

- For time-saving wiring between I/O system and interface modules
- Ribbon cable connection to interface modules (289 and 704 Series) and interface adapter
- W x H x D (mm) 12 x 74.1 x 100

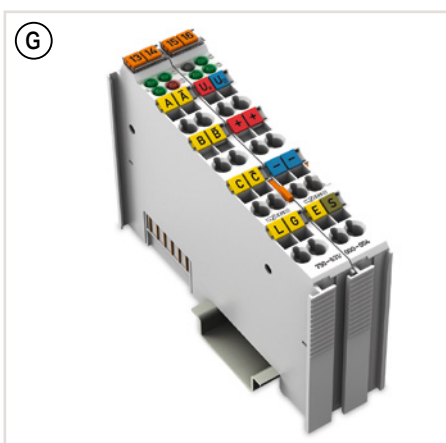
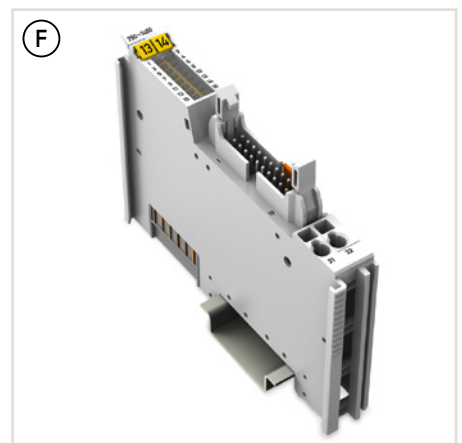

Housing design: double width (G)

- Some modules are integrated into a double housing to address specific technological needs. Despite utilizing the same standardized housing, these modules are twice as wide.
- W x H x D (mm) 24 x 69.8 x 100

Special housing design (H)

- Some modules are integrated into a specialized housing with a specific width and pluggable connectors. The dimensions are specified on the respective catalog page.

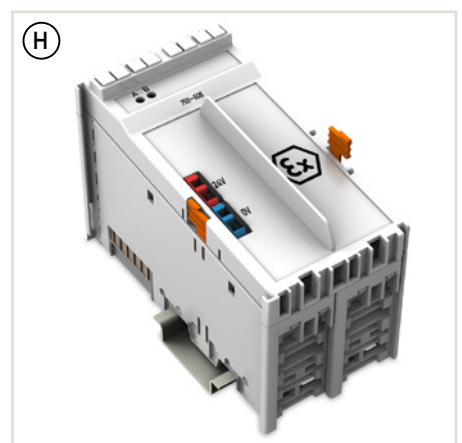

I/O System – 750 and 753 Series Marking and Mounting Accessories



Transparent group marker carriers indicate module type by color.

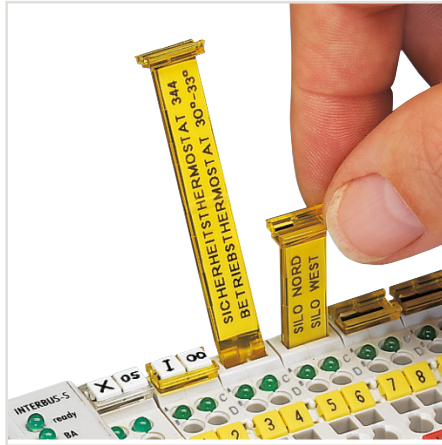

Removable group marker carriers are available for all 750 and 753 Series I/O Modules with a maximum of four LEDs, as well as all fieldbus couplers with a supply module.

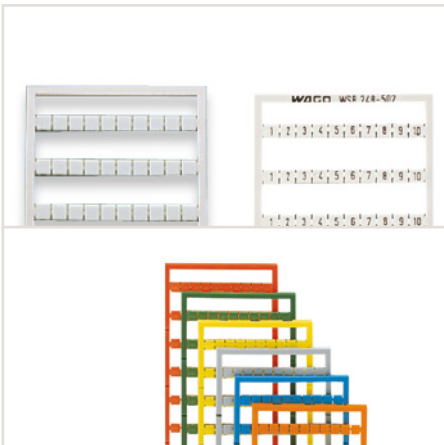

Mini-WSB Quick Marking System, blank, pre-marked and colored; suitable for all 750 and 753 Series I/O Modules.



Marker carrier for one single I/O module (suitable for all 750 and 753 Series I/O Modules); the marker carrier can be accommodated in the upper Mini-WSB marker slot.

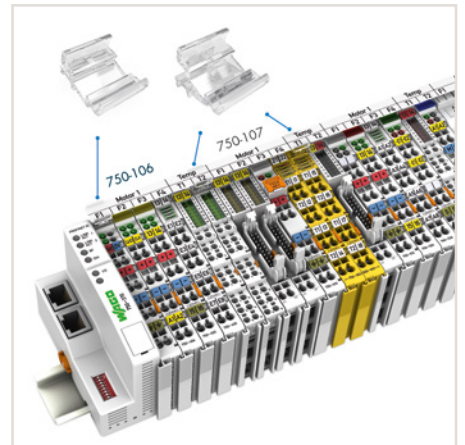

Marker carrier for one I/O node; both carrier models (750-106 and 750-107) permit continuous marking regardless of the I/O module housing used.

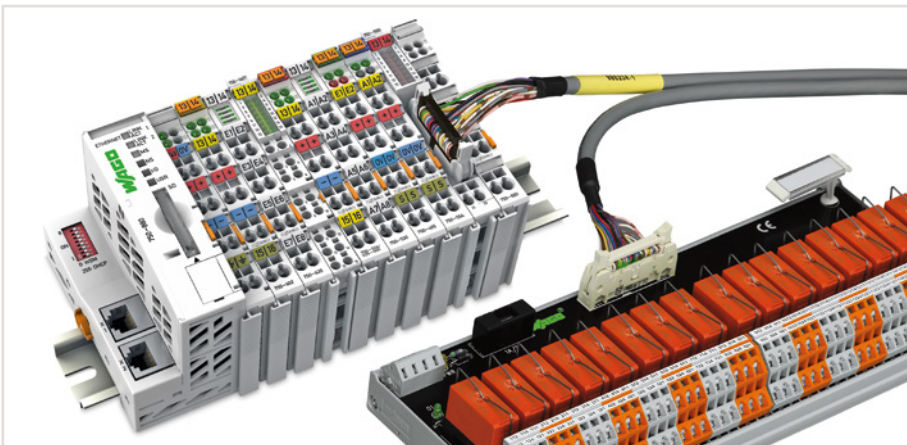

Interface modules for system wiring



Interface cables

I/O System – 750 and 753 Series

Application and Installation Instructions

Power Supply

The internal electronics are powered by the fieldbus coupler. The field-side power supply is electrically isolated via the supply module on the coupler or a separate power supply module. This division enables a separate supply for sensors and actuators. Snapping the I/O modules together automatically routes the supply voltages (system power supply 5 VDC via the data contacts and field supply via the optional power jumper contacts). Supply modules with diagnostics also enable power supply monitoring. This ensures a flexible, user-specific supply design for a station.

Power supply to the electronics is limited by a maximum value. This value depends on the fieldbus coupler used. If the sum of the internal current demand of all the I/O modules should exceed this value, an additional system supply module is necessary. Even in this case, power supply to the field-side supply of 10 A may not be exceeded. However, different power supply modules allow a new power supply, formation of potential groups and the implementation of emergency stop concepts.

Interference-Free in Safety-Related Applications

To easily and safely perform cost-effective, centralized deactivation of complete actuator groups, the actuator's power supply can be switched off using a safety switching device. This can either be performed for each individual actuator or by turning off the power supply to a group of control outputs. In the event of failure, ensure that no interference from other current or power circuits occurs – even when the control voltage is switched off – so the defined safety function properties (logic and time response) remain unchanged.

Some modules are designed to provide interference-free safety functionality. These modules comply with safety requirements up to Category 4 of DIN EN ISO 13849-1:2007. Safety category and performance level depend solely on the safety components and their wiring.

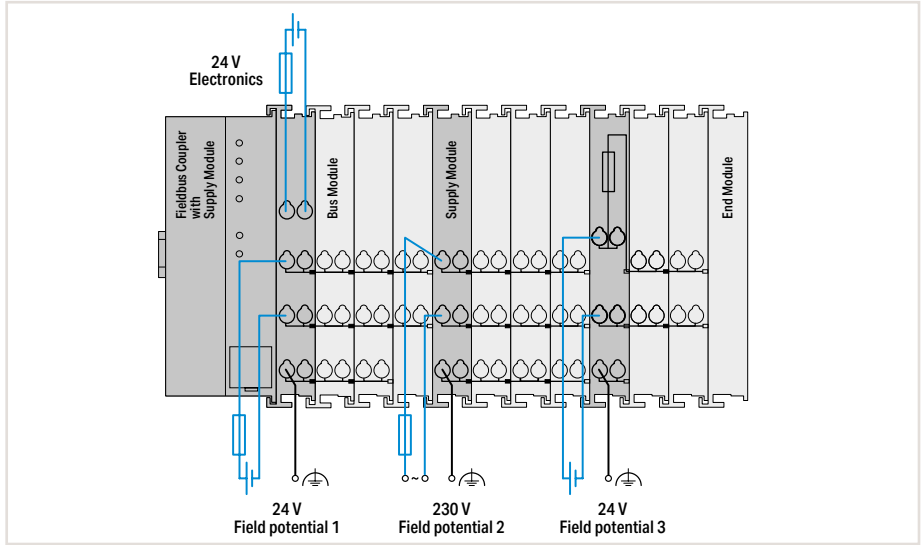

Notice:

WAGO's interference-free I/O modules are not a component of the safety function and do not replace the safety switching device! When using the components in safety functions, the corresponding notes must be observed in the relevant manual.

Notes:

Additional steps must be implemented based on where the I/O system is installed:

Specific field-side power supply filters (750-624) or power supply filters (750-626) are required for marine and onshore/offshore applications.

A specific supply module (750-606) is required to operate intrinsically safe Ex i modules.

Additionally, both supply modules and field-side power supply filters are recommended

when operating intrinsically safe Ex i modules for marine and onshore/offshore applications.

For the 24 VDC power supply of electronics and field, PELV/SELV power supply units are recommended. As part of safety-related applications, they are mandatory. The mixed operation of safe and conventional I/O modules streamlines system configuration. For increased electromagnetic immunity (EMC standard), WAGO offers compact power supply filter modules.

Please refer to the manual for details about the power supply's design.

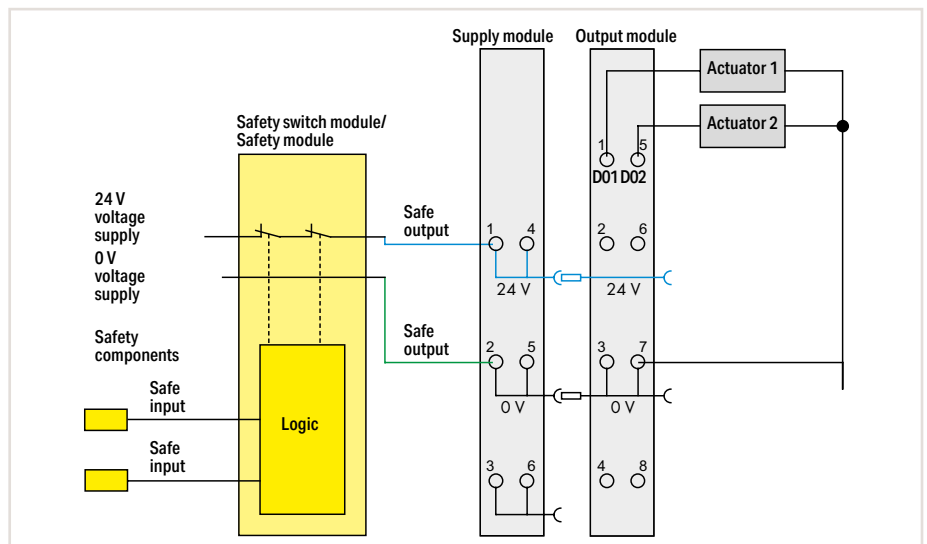

Example: 2-channel, double-pole power supply disconnection

I/O System – 750 and 753 Series

Application and Installation Instructions

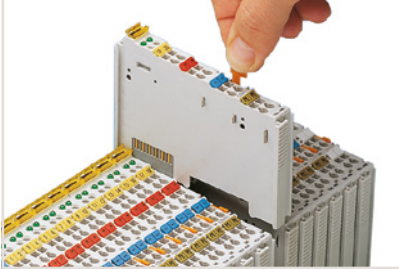

Securing/removing a module from the mounting rail.

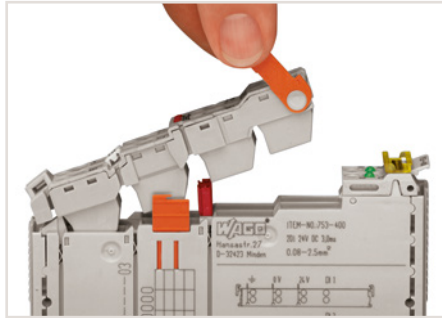

Releasing a pluggable connector.



Optional protection against mismatching of pluggable connectors via coding elements



Service interface for configuring the fieldbus coupler; connectivity via configuration cable or radio adapter

Notice:

For some I/O modules, not all power jumper contacts are made! A module with three power jumper contacts (e.g., 2-channel digital input) cannot be snapped into place behind a module in which not every contact is made.

To increase electromagnetic compatibility (EMC), some components are connected to the DIN-rail by a discharge contact. The DIN-rail must always have a low-resistance connection to the ground potential.

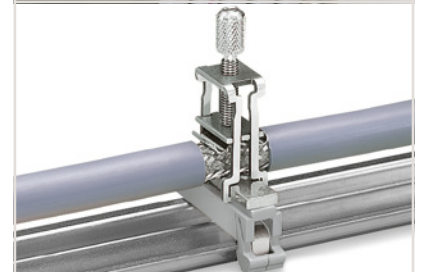

Wide range of accessories available for EMC-compliant installation, including shield connection

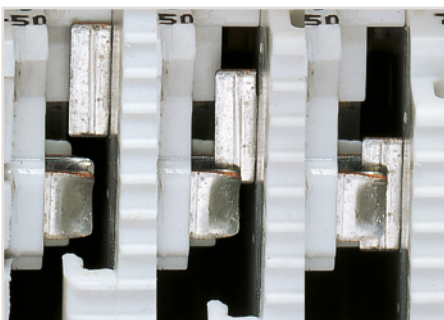

Secure, automatic power supply connection via self-cleaning blade contacts



Secure, automatic data and electronics power supply connection via gold-plated pressure contacts



Securing a cable to the connector.

I/O System – 750 and 753 Series

Item Number Key

Explanation of item number key's components

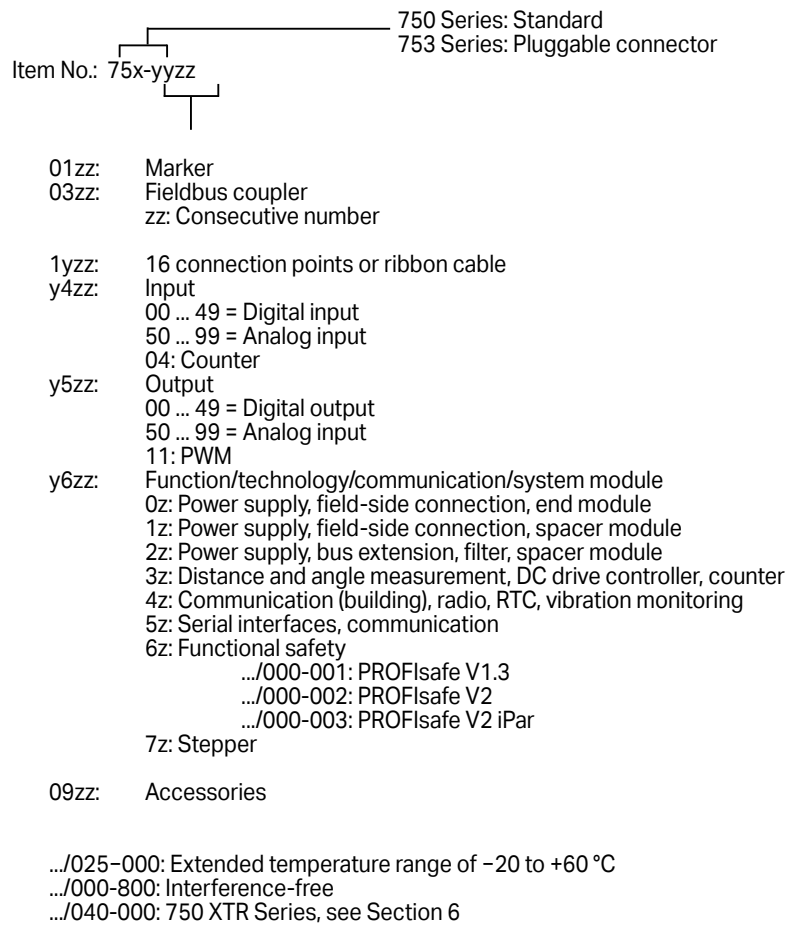

I/O System – 750 and 753 Series

Standards and Rated Conditions

General Specifications	
Supply voltage (system)	24 VDC (–25 % ... +30 %)*; *for all marine-certified fieldbus couplers and I/O modules
Isolation	500 V (system/supply)
Surrounding air temperature (operation)	0 ... +55 °C
Surrounding air temperature (operation) for versions with an extended temperature range	–20 ... +60 °C
Surrounding air temperature (storage)	–40 ... +85 °C
Relative humidity	95 % (non-condensing)
Relative humidity for versions with an extended temperature range	Max. 95 %; short-term condensation per Class 3K6 / IEC EN 60721-3-3 and E DIN 40046-721-3, taking a temperature range of –20 to +60 °C into consideration (except wind-driven precipitation, water and ice formation)
Operating altitude	0 ... 2000 m
Pollution degree	2 per IEC 61131-2
Vibration resistance	0.5g (4g for all marine-certified fieldbus couplers and I/O modules) per IEC 60068-2-6
Shock resistance	15g per IEC 60068-2-27
EMC immunity to interference	Per EN 61000-6-2
EMC emission of interference	Per EN 61000-6-3; EN 61000-6-4
Protection type	IP20
Mounting type	DIN-35 rail mounting
Housing material	Polycarbonate; polyamid 6.6
Exposure to pollutants	Per IEC 60068-2-42 and IEC 60068-2-43
Permissible SO ₂ contaminant concentration at a relative humidity < 75 %	25 ppm
Permissible H ₂ S contaminant concentration at a relative humidity < 75 %	10 ppm
Connection technology	CAGE CLAMP®
Conductor cross section; strip length for Standard modules and couplers: I/O modules, 753 Series: ECO fieldbus couplers:	0.08 ... 2.5 mm ² /28 ... 14 AWG; 8 ... 9 mm/0.31 ... 0.35 inch 0.08 ... 2.5 mm ² /28 ... 14 AWG; 9 ... 10 mm/0.35 ... 0.39 inch 0.08 ... 1.5 mm ² /28 ... 16 AWG; 5 ... 6 mm/0.2 ... 0.24 inch
Connection technology	Push-in CAGE CLAMP®
Conductor cross section; strip length for I/O modules with 16 connection points:	Solid: 0.08 ... 1.5 mm ² /28 ... 16 AWG, Fine-stranded: 0.25 ... 1.5 mm ² /22 ... 16 AWG; 8 ... 9 mm/0.31 ... 0.35 inch
Current carrying capacity (power jumper contacts)	10 A

